

SY88289HL



3.3V, 3.2Gbps High-Gain CML Limiting Amplifier with High-sensitivity Loss-of-Signal Detection

General Description

The SY88289HL low-power, high-sensitivity, limiting post amplifier is designed for use in fiber-optic receivers. The device connects to typical transimpedance amplifiers (TIAs). The linear signal output from TIAs can contain significant amounts of noise and may vary in amplitude over time. The SY88289HL quantizes these signals and outputs CML-level waveforms.

The SY88289HL operates from a single +3.3V power supply, over temperatures ranging from -40°C to $+85^{\circ}\text{C}$. With its wide bandwidth, high gain, and signals with data rates up to 3.2Gbps and as small as 4mV_{PP} , it can be amplified to drive devices with CML/PECL inputs.

The SY88289HL generates a high-gain loss-of-signal (LOS) open-collector TTL output. This function has a high-gain input stage for increased LOS sensitivity. A programmable loss-of-signal level-set pin (LOS_{LVL}) sets the sensitivity of the input amplitude detection. LOS asserts high if the input amplitude falls below the threshold sets by LOS_{LVL} and de-asserts low otherwise. The enable bar input ($/\text{EN}$) de-asserts the true output signal without removing the input signal. The LOS output can be fed back to the $/\text{EN}$ input to maintain output stability under a loss-of-signal condition. Typically, 3.5dB LOS hysteresis is provided to prevent chattering.

All support documentation can be found on Micrel's web site at: www.micrel.com.

Features

- High input sensitivity: 4mV_{PP}
- I/O compatible to Analog Devices' ADN2891
- Single 3.3V power supply
- 125Mbps to 3.2Gbps operation
- Ideal for multi-rate applications
- Low-noise CML data outputs
- High-sensitivity Loss-of-Signal (LOS) detection
- Chatter-free open-collector TTL Loss-of-Signal (LOS) output with an internal $4.75\text{k}\Omega$ pull-up resistor
- TTL $/\text{EN}$ input
- Programmable LOS level set (LOS_{LVL})
- Available in a tiny (3mm x 3mm) 16-pin MLF[®] package

Applications

- PON
- SFP/SFF/GBIC optical transceivers
- Gigabit Ethernet
- 1X and 2X Fibre Channel
- SONET/SDH: OC 3/12/24/48 – STM 1/4/8/16
- Line driver and line receiver

Markets

- FTTX
- Datacom/Telecom

Typical Application

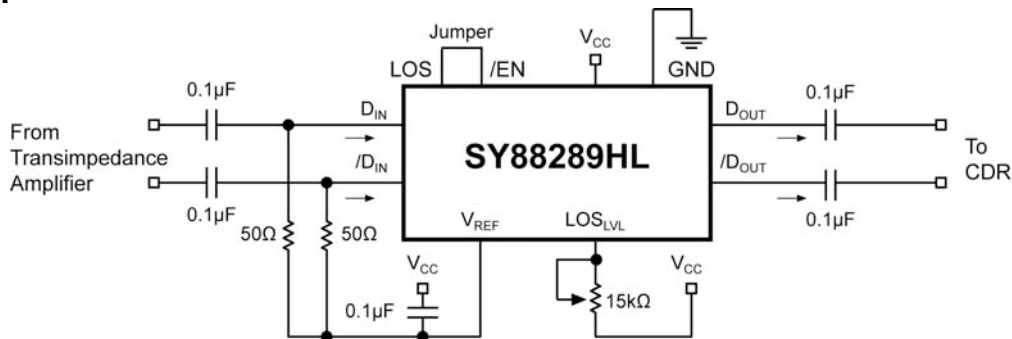

MLF and MicroLeadFrame are registered trademarks of Amkor Technology.

Micrel Inc. • 2180 Fortune Drive • San Jose, CA 95131 • USA • tel +1 (408) 944-0800 • fax +1 (408) 474-1000 • <http://www.micrel.com>

Ordering Information

Part Number	Package Type	Operating Range	Package Marking	Lead Finish
SY88289HLMG	MLF-16	Industrial	289H with Pb-Free bar line indicator	NiPdAu Pb-Free
SY88289HLMGTR ⁽¹⁾	MLF-16	Industrial	289H with Pb-Free bar line indicator	NiPdAu Pb-Free

Note:

1. Tape and Reel.

Pin Configuration

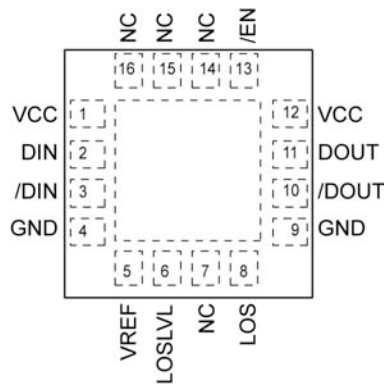

16-Pin MLF[®] (MLF-16)

Pin Description

Pin Number	Pin Name	Type	Pin Function
1, 12	VCC	Power Supply	Positive power supply.
2	DIN	Data Input	True data input.
3	/DIN	Data Input	Complementary data input.
4, 9	GND	Ground	Device ground.
5	VREF		Reference voltage: Placing a capacitor here to VCC helps stabilize LOS _{LVL} .
6	LOSLVL	Input	Loss-of-signal Level Set: a resistor from this pin to VCC sets the threshold for the data input amplitude at which LOS will be asserted.
7, 14, 15, 16	N/C		No connect.
8	LOS	Open-collector TTL output w/ internal 4.75kΩ pull-up resistor	Loss-of-signal: asserts high when the data input amplitude falls below the threshold sets by LOS _{LVL} .
10	/DOUT	CML Output	Complementary data output.
11	DOUT	CML Output	True data output.
13	/EN	TTL Input: Default is HIGH.	/Enable: This input enables the outputs when it is LOW. Note that this input is internally connected to a 25kΩ pull-up resistor and will default to a logic HIGH state if left open.

Absolute Maximum Ratings⁽¹⁾

Supply Voltage (V_{CC})	0V to +4.0V
Input Voltage (DIN, /DIN)	0 to V_{CC}
Output Current (I_{OUT})	
Continuous	± 25 mA
/EN Voltage	0 to V_{CC}
V_{REF} Current	-800 μ A to +500 μ A
LOS_{LVL} Voltage	V_{REF} to V_{CC}
Lead Temperature (soldering, 20sec.)	260°C
Storage Temperature (T_s)	-65°C to +150°C

Operating Ratings⁽²⁾

Supply Voltage (V_{CC})	+3.0V to +3.6V
Ambient Temperature (T_A)	-40°C to +85°C
Junction Temperature (T_J)	-40°C to +125°C
Junction Thermal Resistance ⁽³⁾	
MLF [®] (θ_{JA})	
Still-air	61°C/W
MLF [®] (Ψ_{JB})	
Junction-to-board	38°C/W

DC Electrical Characteristics

$V_{CC} = 3.0V$ to $3.6V$; $R_L = 50\Omega$ to V_{CC} ; $T_A = -40^\circ C$ to $+85^\circ C$.

Symbol	Parameter	Condition	Min	Typ	Max	Units
I_{CC}	Power Supply Current	No output load		42	62	mA
LOS_{LVL}	LOS_{LVL} Voltage		V_{REF}		V_{CC}	V
V_{OH}	CML Output HIGH Voltage		$V_{CC}-0.020$	$V_{CC}-0.005$	V_{CC}	V
V_{OL}	CML Output LOW Voltage	$V_{CC} = 3.3V$	$V_{CC}-0.475$	$V_{CC}-0.400$	$V_{CC}-0.350$	V
V_{OFFSET}	Differential Output Offset				± 80	mV
V_{REF}	Reference Voltage			$V_{CC}-1.28$		V
V_{IHCMR}	Input Common Mode Range		GND+2.0		V_{CC}	V

TTL DC Electrical Characteristics

$V_{CC} = 3.0V$ to $3.6V$; $R_L = 50\Omega$ to V_{CC} ; $T_A = -40^\circ C$ to $+85^\circ C$.

Symbol	Parameter	Condition	Min	Typ	Max	Units
V_{IH}	/EN Input HIGH Voltage		2.0			
V_{IL}	/EN Input LOW Voltage				0.8	V
I_{IH}	/EN Input HIGH Current	$V_{IN} = 2.7V$ $V_{IN} = V_{CC}$			20 100	μA μA
I_{IL}	/EN Input LOW Current	$V_{IN} = 0.5V$	-300			μA
V_{OH}	LOS Output High Level	$V_{OUT} \geq 3.3V, I_{OH(MAX)} < 160\mu A$ $V_{OUT} < 3.3V, I_{OH(MAX)} < 160\mu A$	2.4 2.0			V V
V_{OL}	LOS Output LOW Level	Sinking 2mA			0.5	V

Notes:

1. Permanent device damage may occur if absolute maximum ratings are exceeded. This is a stress rating only and functional operation is not implied at conditions other than those detailed in the operational sections of this data sheet. Exposure to absolute maximum rating conditions for extended periods may affect device reliability.
2. The data sheet limits are not guaranteed if the device is operated beyond the operating ratings.
3. Package thermal resistance assumes exposed pad is soldered (or equivalent) to the device's most negative potential (GND) on the PCB. Ψ_{JB} uses 4-layer (θ_{JA}) in still-air-number, unless otherwise stated.

AC Electrical Characteristics

$V_{CC} = 3.0V$ to $3.6V$; $R_L = 50\Omega$ to V_{CC} ; $T_A = -40^\circ C$ to $+85^\circ C$.

Symbol	Parameter	Condition	Min	Typ	Max	Units
t_r, t_f	Output Rise/Fall Time (20% to 80%)	Note 4		60	120	ps
t_{JITTER}	Deterministic Random	Note 5 Note 6		15 5		ps _P ps _{RMS}
V_{ID}	Differential Input Voltage Swing	Figure 1	4		1800	mV _{PP}
V_{OD}	Differential Output Voltage Swing	$V_{ID} \geq 6mV_{PP}$, Figure 1	700	800	950	mV _{PP}
T_{OFF}	LOS Release Time			2	10	ns
T_{ON}	LOS Assert Time			2	10	ns
LOS_{AL}	Low LOS Assert Level	$R_{LOSLVL} = 15k\Omega$, Note 8		3		mV _{PP}
LOS_{DL}	Low LOS De-assert Level	$R_{LOSLVL} = 15k\Omega$, Note 8		4.5		mV _{PP}
HYS_L	Low LOS Hysteresis	$R_{LOSLVL} = 15k\Omega$, Note 7		3.5		dB
LOS_{AM}	Medium LOS Assert Level	$R_{LOSLVL} = 5k\Omega$, Note 8	2	5		mV _{PP}
LOS_{DM}	Medium LOS De-assert Level	$R_{LOSLVL} = 5k\Omega$, Note 8		7.5	11	mV _{PP}
HYS_M	Medium LOS Hysteresis	$R_{LOSLVL} = 5k\Omega$, Note 7	2	3.5	4.5	dB
LOS_{AH}	High LOS Assert Level	$R_{LOSLVL} = 100\Omega$, Note 8	8	12		mV _{PP}
LOS_{DH}	High LOS De-assert Level	$R_{LOSLVL} = 100\Omega$, Note 8		18	23	mV _{PP}
HYS_H	High LOS Hysteresis	$R_{LOSLVL} = 100\Omega$, Note 7	2	3.5	4.5	dB
B_{-3dB}	3dB Bandwidth			2		GHz
$A_{V(Diff)}$	Differential Voltage Gain		40	46		dB
S_{21}	Single-ended Small-Signal Gain		34	40		dB

Notes:

- Amplifier in limiting mode. Input is a 200MHz square wave.
- Deterministic jitter measured using 3.2Gbps K28.5 pattern, $V_{ID} = 10mV_{PP}$.
- Random jitter measured using 3.2Gbps K28.7 pattern, $V_{ID} = 10mV_{PP}$.
- This specification defines electrical hysteresis as $20\log$ (LOS De-assert/LOS Assert). The ratio between optical hysteresis and electrical hysteresis is found to vary between 1.5 and 2, depending upon the level of received optical power and ROSA characteristics. Based upon that ratio, the optical hysteresis corresponding to the electrical hysteresis range 2dB-4.5dB, as shown in the AC characteristics table, will be 1dB-3dB.
- See "Typical Operating Characteristics" for a graph showing how to choose a particular R_{LOSLVL} for a particular LOS assert and its associated de-assert amplitude.

Typical Operating Characteristics

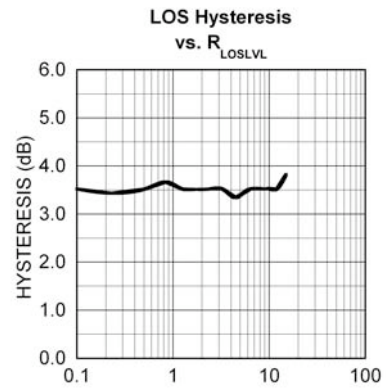
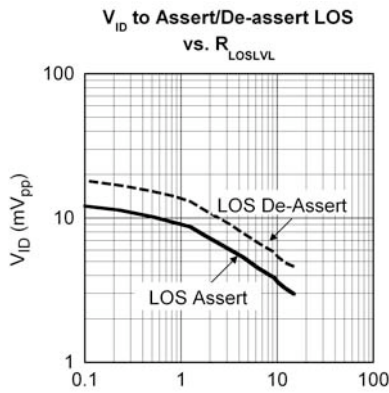

Functional Characteristics

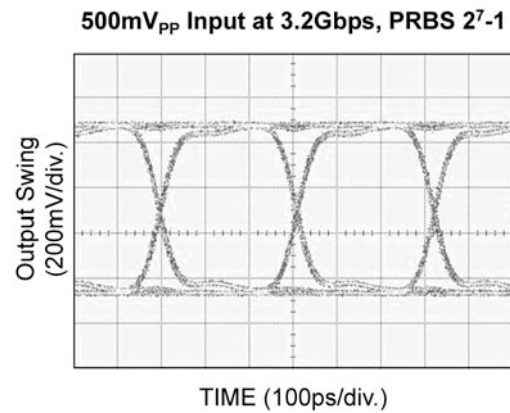
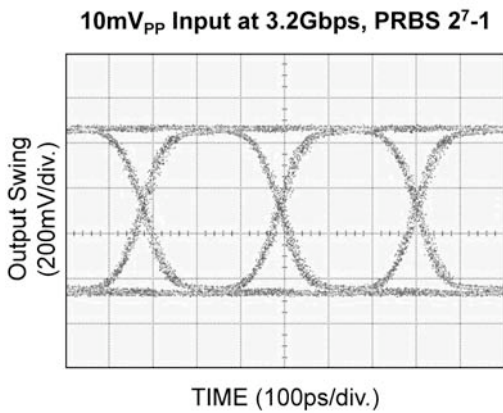
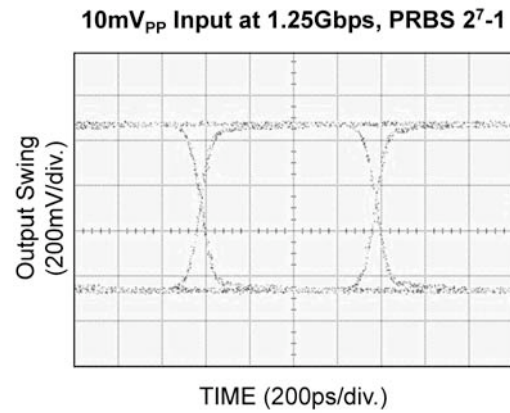
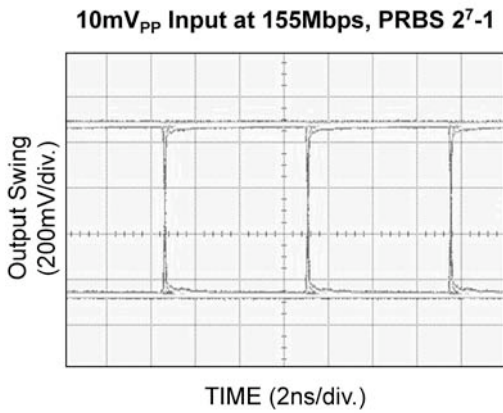

Functional Block Diagram

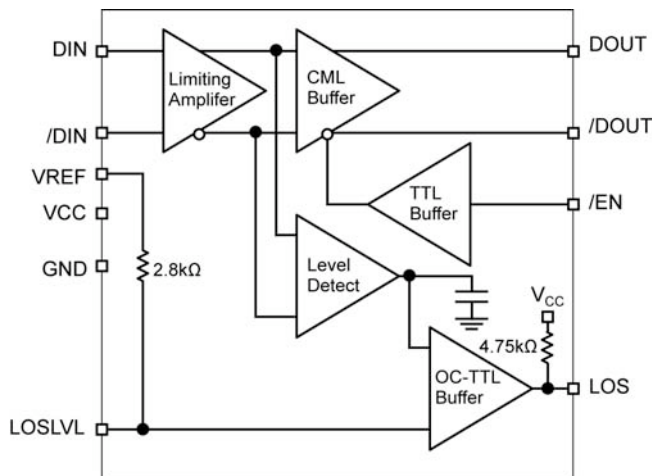

Detailed Description

The SY88289HL high-sensitivity limiting post amplifier operates from a single +3.3V power supply, over temperatures from -40°C to $+85^{\circ}\text{C}$. Signals with data rates up to 3.2Gbps and as small as 4mV_{PP} can be amplified. Figure 1 shows the allowed input voltage swing. The SY88289HL generates a LOS output. LOSLVL sets the sensitivity of the input amplitude detection.

Input Amplifier/Buffer

Figure 2 shows a simplified schematic of the SY88289HL's input stage. The high-sensitivity of the input amplifier allows signals as small as 4mV_{PP} to be detected and amplified. The input amplifier also allows input signals as large as $1800\text{mV}_{\text{PP}}$. Input signals below 6mV_{PP} are linearly amplified with a typical 46dB differential voltage gain. Since it is a limiting amplifier, the SY88289HL outputs typically 800mV_{PP} voltage-limited waveforms for input signals that are greater than 6mV_{PP} . Applications requiring the SY88289HL to operate with high-gain should have the upstream TIA placed as close as possible to the SY88289HL's input pins to ensure the best performance of the device.

Output Buffer

The SY88289HL's CML output buffer is designed to drive 50Ω lines. The output buffer requires appropriate termination for proper operation. An external 50Ω resistor to V_{CC} for each output pin provides this. Figure 3 shows a simplified schematic of the output stage.

Loss-of-Signal

The SY88289HL generates a chatter-free LOS open-collector TTL output with an internal $4.75\text{k}\Omega$ pull-up resistor, as shown in Figure 4. LOS is used to determine that the input amplitude is large enough to be considered a valid input. LOS asserts high if the input amplitude falls below the threshold sets by LOSLVL and de-asserts low otherwise. LOS can be fed back to the enable bar (/EN) input to maintain output stability under a loss of signal condition. /EN de-asserts the true output signal without removing the input signals. Typically, 3.5dB LOS hysteresis is provided to prevent chattering.

Loss-of-Signal Level Set

A programmable LOS level-set pin (LOSLVL) sets the threshold of the input amplitude detection. Connecting an external resistor between V_{CC} and LOSLVL sets the voltage at LOSLVL . This voltage ranges from V_{CC} to V_{REF} . The external resistor creates a voltage divider between V_{CC} and V_{REF} , as shown in Figure 5.

Hysteresis

The SY88289HL typically provides 3.5dB LOS electrical hysteresis. By definition, a power ratio measured in dB is $10\log(\text{power ratio})$. Power is calculated as V_{IN}^2/R for an electrical signal. Hence, the same ratio can be stated as $20\log(\text{voltage ratio})$. While in linear mode, the electrical voltage input changes linearly with the optical power and therefore, the ratios change linearly. Thus, the optical hysteresis in dB is half the electrical hysteresis in dB given in the data sheet. Since the SY88289HL is an electrical device, this data sheet refers to hysteresis in electrical terms. With 3.5dB LOS hysteresis, a voltage factor of 1.5 is required to assert or de-assert LOS.

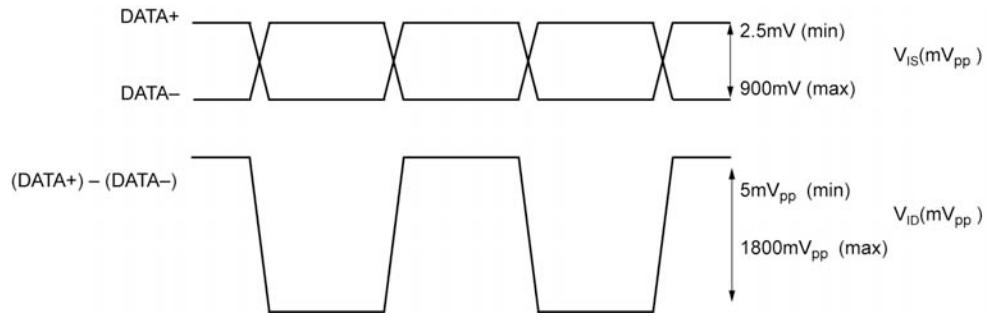

Figure 1. V_{IS} and V_{ID} Definition

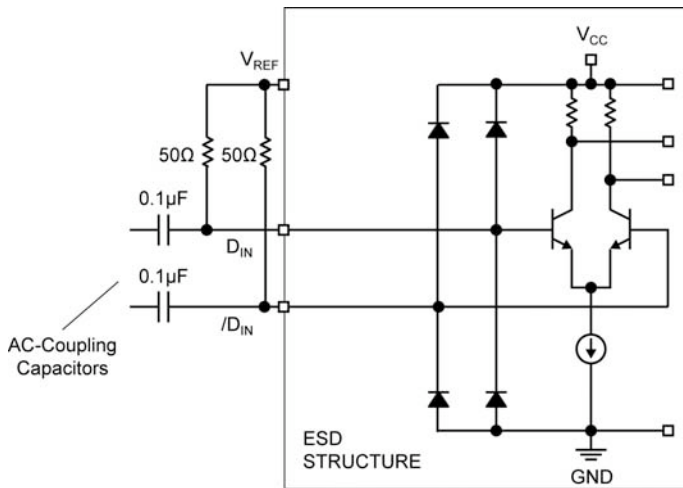

Figure 2. Input Structure

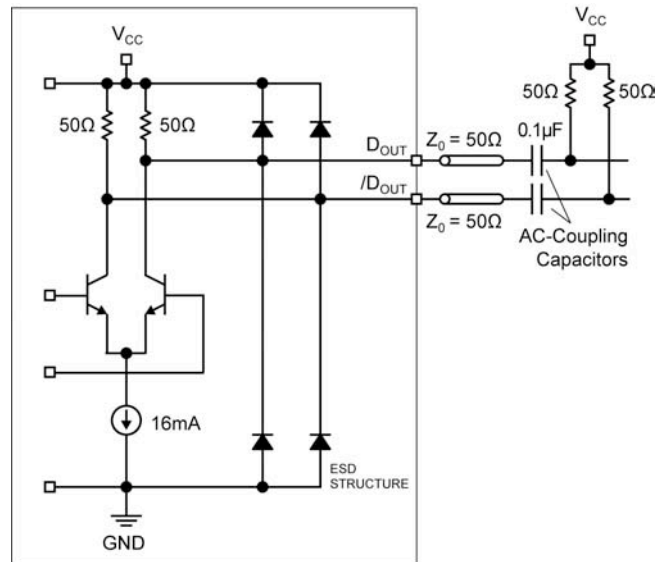

Figure 3. Output Structure

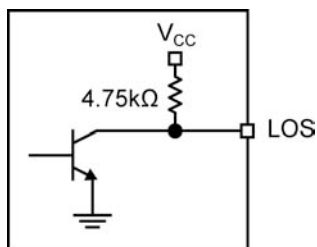

Figure 4. Input Structure

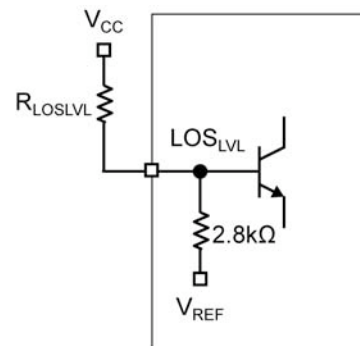
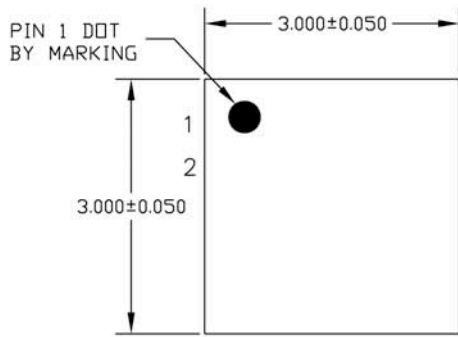
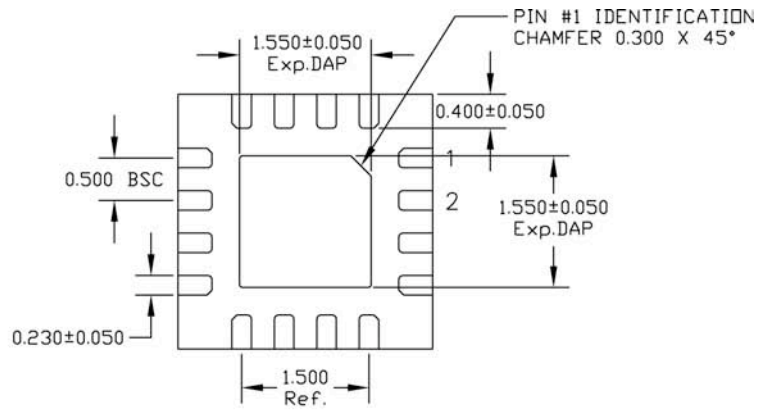

Figure 5. LOS_{LVL} Setting Circuit

Package Information



TOP VIEW



BOTTOM VIEW

- NOTE:
1. ALL DIMENSIONS ARE IN MILLIMETERS.
 2. MAX. PACKAGE WARPAGE IS 0.05 mm.
 3. MAXIMUM ALLOWABLE BURRS IS 0.076 mm IN ALL DIRECTIONS.
 4. PIN #1 ID ON TOP WILL BE LASER/INK MARKED.
- ⚠ APPLIED ONLY FOR TERMINALS.
 - ⚠ APPLIED FOR EXPOSED PAD AND TERMINALS.

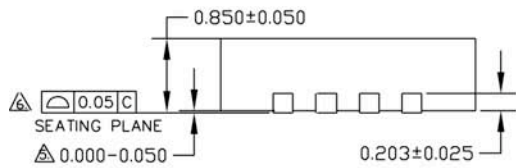

SIDE VIEW

16-Pin (3mm x 3mm) MLF[®] (MLF-16)

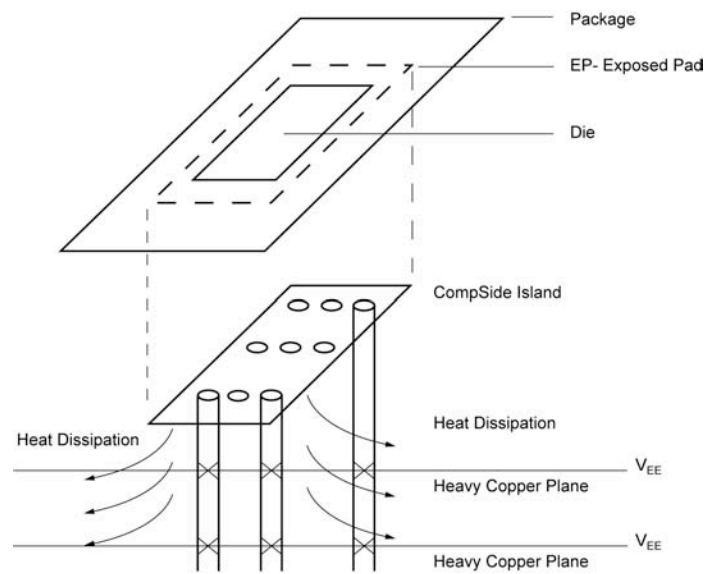

PCB Thermal Consideration for 16-Pin MLF[®] Package

Package Notes:

1. Package meets Level 2 qualification.
2. All parts are dry-packaged before shipment.
3. Exposed pad must be soldered to a ground for proper thermal management.

MICREL, INC. 2180 FORTUNE DRIVE SAN JOSE, CA 95131 USA
 TEL +1 (408) 944-0800 FAX +1 (408) 474-1000 WEB <http://www.micrel.com>

The information furnished by Micrel in this data sheet is believed to be accurate and reliable. However, no responsibility is assumed by Micrel for its use. Micrel reserves the right to change circuitry and specifications at any time without notification to the customer.

Micrel Products are not designed or authorized for use as components in life support appliances, devices or systems where malfunction of a product can reasonably be expected to result in personal injury. Life support devices or systems are devices or systems that (a) are intended for surgical implant into the body or (b) support or sustain life, and whose failure to perform can be reasonably expected to result in a significant injury to the user. A Purchaser's use or sale of Micrel Products for use in life support appliances, devices or systems is a Purchaser's own risk and Purchaser agrees to fully indemnify Micrel for any damages resulting from such use or sale.

© 2007 Micrel, Incorporated.